

DemiNo® - Impact Whirl Mill

Worldwide exclusive, multi-patented processing technology. Available only at NOLL's! It unites pin mill and whirlwind principles and helps save an entire processing step: direct grinding, no extra classifying needed. The pioneering solution for almost any product application, from food to minerals - a universal genius and fantastic energy saver.

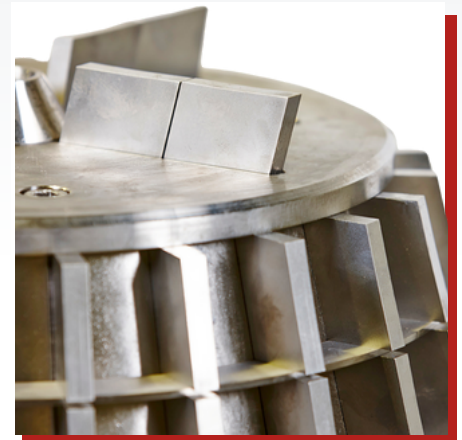

What makes this mill unique

- automatic rotor direction change for longer service life
- low abrasion through hard metal equipment
- easy replacement of wear parts
- fast cleaning and low maintenance
- milling and homogenization up to Mohs hardness 7
- abrasive and sticky products, special processing
- cryogenic grinding, mill-drying, inert gas operation

All NOLL systems and designs stand out because they

- use far less energy than other systems
- reduce operating costs considerably
- suit almost any application and are remarkably versatile

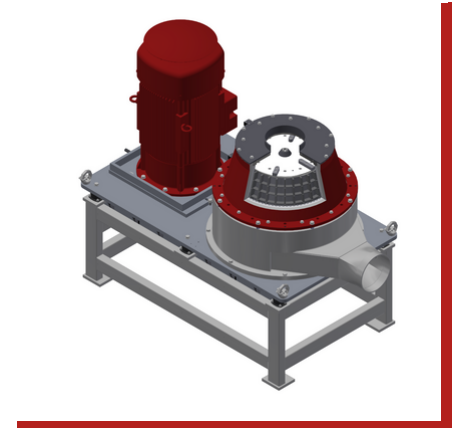

DEMINO® - SERIES	DEMINO® 3125	DEMINO® 2250	DEMINO® 2500	DEMINO® 2700	DEMINO® 2900
CAPACITY (kg/h)	up to 200	up to 1.000	up to 2.500	up to 4.000	up to 7.000
FEED SIZE RANGE (mm)	< 2.0	< 5.0	< 10.0	< 10.0	< 15.0
FINENESS (D 97 µm)	25 - 1.000	30 - 1.000	35 - 1.500	40 - 1.500	40 - 1.500
MAX. AIRFLOW (m³/h)	150	500	2.000	4.000	8.000
ROTOR DRIVE (kW)	7.5	18.5/22	37/45	75/90	132/160
RADIAL FAN DRIVE (kW)	1.0	5.5	11	15	22
DIMENSIONS (approx. h/w/d m)	0.7 x 0.4 x 0.8	1.0 x 1.6 x 1.1	1.4 x 0.9 x 1.7	1.5 x 1.1 x 2.0	1.6 x 1.3 x 2.3

CONTACT

AUFBEREITUNGSTECHNOLOGIE  NOLL® GMBH

Phone +49 (0) 82 34/80 503-0
info@noll.eu | www.noll.eu

Edisonstraße 11 B
D-86399 Bobingen

